

WESTFIELD®

WR60

WR80

WR100

W130

NEW W130
31' & 36'



WR & W Series Grain Augers

MD EMD

The Convenience of a Self Contained Unit

PTO

MD

Our unique Motor Drive auger doesn't use a gear box. Power is transferred through two needle bearing universal joints for maximum power to the flighting. The engine mounts crosswise for easier, safer starting from the side of the auger. The motor mount (for either gas engine or electric motor) is self leveling at all auger positions. Double belt drive with adjustable tension is standard on 8" augers. Belts are easily replaced by removing and replacing the pulley shield and two bolts (see operators manual).



PTO-BD

Our popular PTO Belt Drive has belts running from the gear box to a jackshaft near the auger wheels. This places the tractor away from the auger intake, allowing added working room and longer reach into bins. The drive can be positioned for right or left hand drive. Anti-belt-whip guides, non-separable 48" PTO driveline (65" extended), and handy driveline transport saddle are standard. Single drive belt on 6" models and double drive belts on 8" models are tension adjustable.

EMD

Electric Motor Drive is available for all auger sizes. The motor mounts firmly to the gear box and auger tube. A threaded adjustment allows positive belt tension. Double belt drive is standard on augers up to 8" x 51 feet. Triple belt drive is standard on longer 8" and all 10" models.



PTO-SD

Our PTO Shaft Drive models feature a gear box connected directly to the auger driveshaft with coupler and shear bolt for the most positive auger drive available. The gear box can be flipped for right or left hand drive. A nonseparable 60" PTO driveline (extends to 80") and a handy driveline transport saddle are standard.

Select the Drive Style to Suit Your Needs

Belt & Shaft Drives - The Traditional Options



Powder Coat Finish

Powder coating is an advanced method of applying a protective finish.

The powder used for this process is a mixture of finely ground particles of pigment and resin, which is sprayed onto the surface of every Westfield auger.

The charged powder particles adhere to the electrically grounded surfaces until heated and fused into a smooth coating in our curing oven.

The result is a much thicker coating with a finish that is more durable than conventional liquid paint.

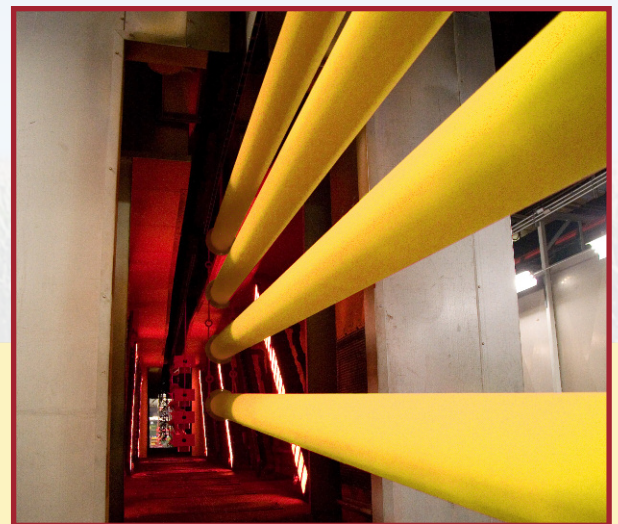

These Built-In Features Add Value!

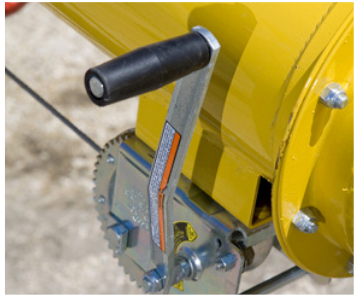

Winch

Safety winch with automatic brake is sized and geared to match the auger. The strong 1/4" galvanized aircraft type cable has 7000 lbs. break strength.



Rollertrack Shoe

Roller with oiled hardwood bearings reduces effort needed to raise auger.



Track

A roll-formed track under the auger tube provides excellent rigid support. Augers 46' and up have heavy cable trussing for extra support & positive tube alignment.



Gear Boxes

Gear boxes have forged steel gears with tapered roller bearings running in oil for years of dependable service and can be flipped for right or left hand PTO drive.



Intake

The auger intake is shielded for operator protection and has a long one pin quick-remove clevis that is easily replaced. Intake flight has new welded Wear Edge for long life with special low pitch for proven added capacity. Greaseable Oilite bearing centers flight reducing vibration and wear.



Flighting

Flighting is mounted and stretched on the flight shaft with hydraulic power and then welded in place for smoother running and longer life. All flight connections are timed for smooth grain flow.



Driveshaft Bearings

Driveshaft bearings constructed of durable oil-impregnated hard-wood, for long, quiet operation can be easily replaced if needed with no disassembly of drive-shaft. Bearing brackets are factory jig welded for precise alignment.



Other Bearings

All bearings are matched to auger size from the flange type ball bearings on smaller augers to the heavy duty cast iron flange ball bearings on larger models.

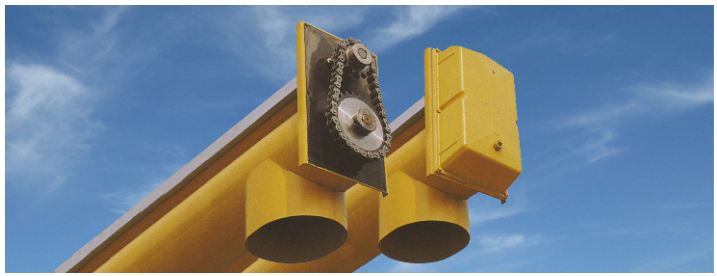

Lubricated Upper Drive

Heavy duty hardened steel sprockets and high speed roller chain are sized to match auger length and diameter. Lubricated upper drive adds years of life to sprockets and drive chain. Now standard equipment on all models. Safety shield shown removed for clarity. DO NOT operate auger with safety shields removed.



Under Carriage

Undercarriages of heavy steel tubing are designed for each specific auger length for better balance and stability. Added cross bracing is used on larger models. Upper lift arms sit back from the axle and quickly tuck away for excellent bin eave clearance. Wide axles provide added stability. High speed wheels with cast iron hubs and tapered roller bearings are standard.

WESTFIELD®

The Westfield Name

When you make only one product, you get to be very good at it. For over 50 years, Westfield has developed and refined the best grain augers available. We've learned what farmers want – affordable, simple, straight-forward designs for labor saving performance and dependability. Westfield's grain augers are built with the best materials, components and features to provide value and performance you can count on. This is our promise and the reason why we're the industry leader.

Add These Optional Features

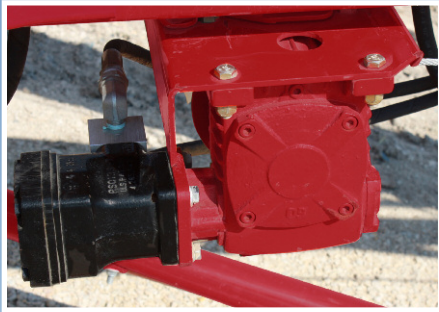

Hydraulic Winch

Raise and lower auger from the convenience of your tractor seat. High capacity winch with automatic break.



Flex Spout

Optional five section bucket flex spout directs grain flow and reduces spillage. Several sizes available in polyethylene or galvanized steel.



Poly Hoppers

Durable, flexible poly hoppers allow easy dumping with minimum spillage. "V" type hopper fits augers to 8" diameter. Big Round Hopper fits larger augers to 10" diameter.



Swivel Arc Kits

For circular bin set-ups, Westfield augers can be fitted with a Swivel Arc Kit to allow movement in a circle. Wheels can be moved back to regular position.



Speed Reducer Kit

The speed reducer lowers the auger flight speed to accommodate slower feeding of grains for dryers and feed systems. This option reduces wear on the auger, uses less power and allows for easier start up under load.

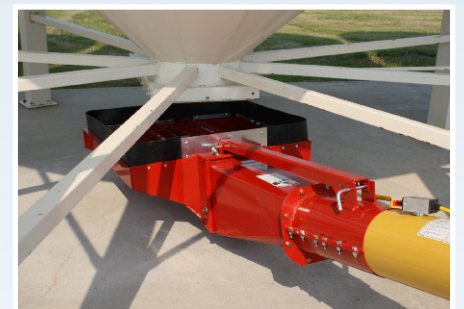

NEW WR Hopper

Optional intake hopper makes it easier to unload bins and fill trucks without the hassle of a poly hopper.

Design

Westfield augers are better by design. Each is engineered and designed for its particular size, meaning weight and strength are properly proportioned, balance is correct, and everything fits and works like it should.

Choice

Westfield still gives you the biggest choice in the industry. Pick the exact size, capacity and drive style you want. Select from 6", 8", 10", or 13" diameters in lengths from 26' to 71'. Choose from PTO belt or shaft drive, gas motor and two electric motor drives depending on your needs and preference.

Value

When comparing design, construction and choice with price, we're sure you'll find Westfield augers are the top value.

Engineered for Safety, Dependability and Value

HEIGHT, REACH & WHEEL TREAD SPECIFICATIONS

	A	B	C	D	E	F	G	H	I	WHEEL TREAD
	Height Lowered	Height Halfway	Height Raised	Reach Lowered	Reach Halfway	Reach Raised	Height at Liftarms	Height at Wheels	Intake Reach	
26'	6'5"	12'8"	17'11"	10'9"	9'5"	7'3"	7'9"	11'4"	6'10"	68"
31'	7'8"	15'1"	21'6"	13'9"	12'0"	9'3"	8'10"	12'10"	7'8"	70"
36'	9'0"	17'4"	24'10"	16'3"	14'3"	11'2"	10'0"	14'4"	8'11"	82"
41'	9'7"	20'2"	28'7"	18'8"	16'4"	12'8"	11'6"	16'4"	10'2"	88"
46'	10'10"	22'7"	31'6"	20'11"	18'3"	14'3"	12'9"	18'1"	11'6"	88"
51'	11'11"	25'0"	35'0"	23'1"	20'2"	15'10"	14'2"	19'11"	12'10"	94"
56'	11'5"	26'0"	38'0"	25'0"	21'6"	16'2"	16'10"	23'2"	13'1"	112"
61'	11'8"	28'4"	41'0"	27'4"	24'4"	19'0"	17'2"	24'3"	16'2"	112"
71'	12'10"	33'0"	47'0"	31'8"	28'1"	22'6"	19'8"	27'6"	18'5"	118"
W130										
NEW 31'	7'7"	13'9"	19'3"	13'	11'9"	9'8"	9'	12'5"	8'	112"
NEW 36'	7'10"	15'4"	22'1"	15'	14'2"	12'11"	9'6"	12'10"	11'1"	112"
41'	10'0"	19'9"	28'3"	16'5"	14'5"	11'3"	-	-	-	94"
51'	10'9"	21'10"	35'5"	22'4"	20'2"	15'3"	-	-	-	112"
61'	11'7"	25'8"	41'1"	27'5"	24'10"	20'0"	-	-	-	118"
71'	12'11"	30'10"	47'0"	32'3"	29'5"	23'1"	-	-	-	124"

Heights measured from bottom of auger spout to ground.

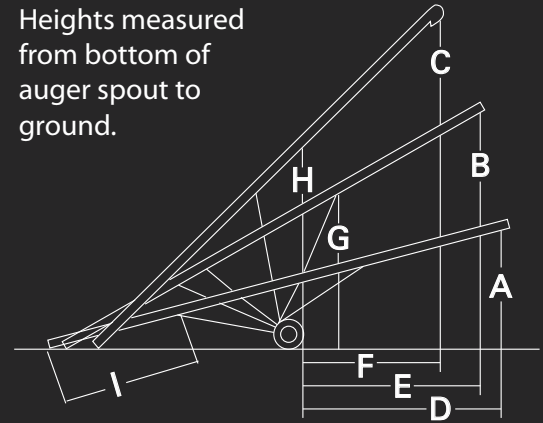

DRIVE OPTIONS

	MD		EMD				PTO-BD		PTO-SD			
	6"	8"	6"	8"	10"	13"	6"	8"	6"	8"	10"	13"
26'	•	•	•	•								
31'	•	•	•	•	•	•			•	•	•	•
36'	•	•	•	•		•	•	•	•	•		•
41'	•	•	•	•	•	•	•	•	•	•	•	•
46'				•				•		•		
51'			•	•	•			•	•	•	•	•
56'				•						•		
61'			•	•	•				•	•	•	•
71'				•	•					•	•	•

HORSEPOWER REQUIREMENTS

	6"			8"			10"		13"	
	GAS HP	PTO HP	ELEC. HP	GAS HP	PTO HP	ELEC. HP	GAS HP	ELEC. HP	PTO HP	ELEC. HP
26'	10	-	3	14	-	3-5	-	-	-	-
31'	10	-	3	16	-	5	30	7.5-10	40	20
36'	12	-	3	16	-	5-7.5	-	-	40-50	20-25
41'	12	-	3	16	-	5-7.5	40	10-15	50	25
46'	-	-	-	18	-	7.5	-	-	-	-
51'	-	20	5	18	-	7.5	45	15-20	70	NA
56'	-	-	-	-	30	10	-	-	-	-
61'	-	25	7.5	-	35	10	55	20	80	NA
71'	-	-	-	-	45	15	60	20-25	90	NA

Under reasonable conditions high moisture grain will require more horsepower



SAFETY FIRST!

We know you work long and hard, especially during harvest. Please take the time to put safety first:

Westfield augers are designed with operator safety in mind and incorporate many safety features. Everyone operating an auger must read and understand the operator's manual and safety decals before attempting to operate the unit. Do not modify this implement in any way. Use only for intended purposes. Keep all safety shields in place while operating. Never operate with any safety shields or guard removed or modified. Never transport the unit in a raised position. Check overhead before raising. Never attempt to service the auger while it is running. Keep children, pets and untrained personnel away from work area.

WESTFIELD®

Box 39, Rosenort, Manitoba, R0G 1W0 Toll Free: 1-866-467-7207 Web: www.grainaugers.com Email: sales@grainaugers.com

